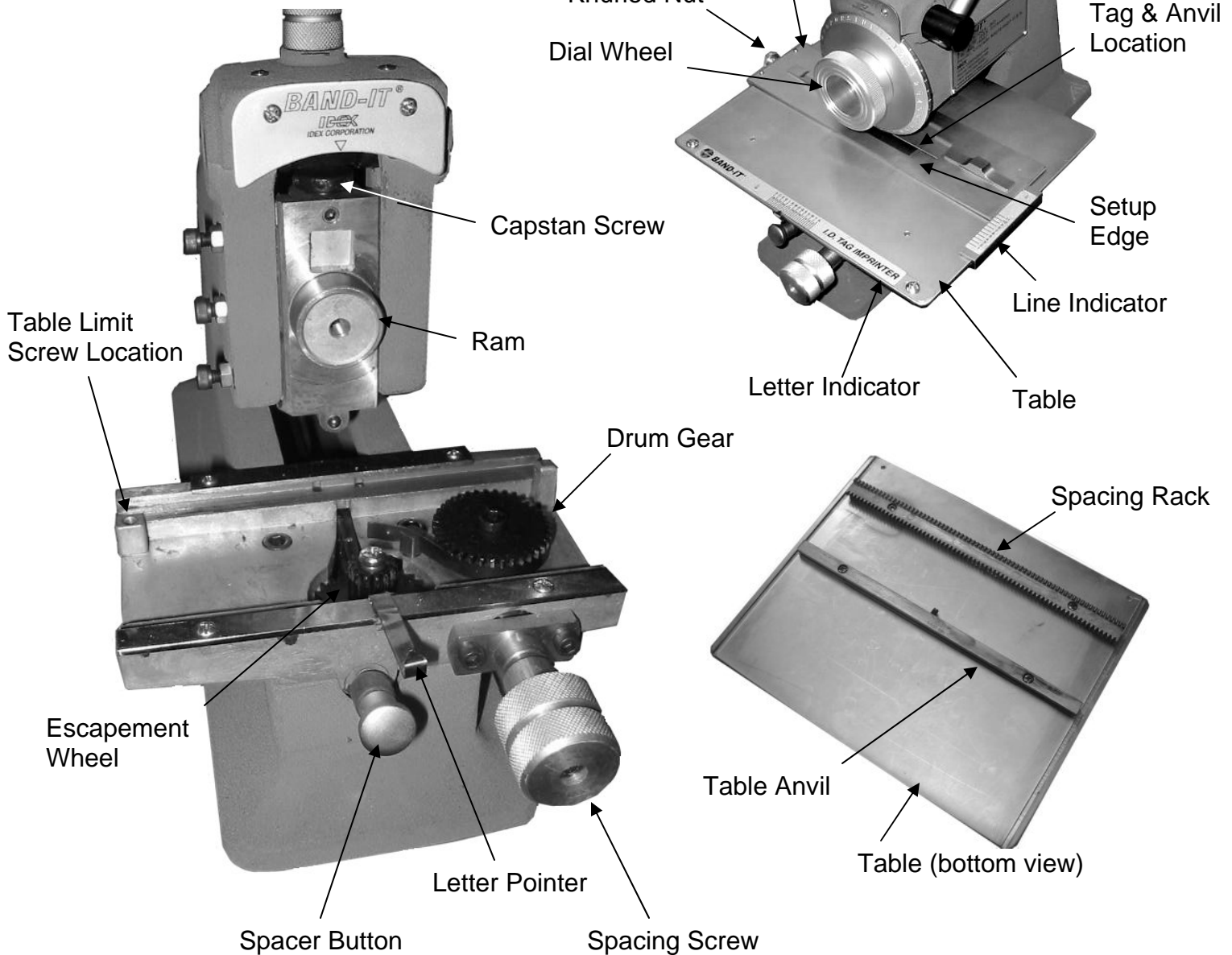
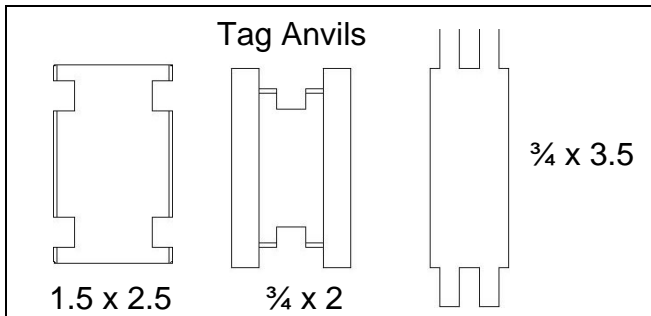

Table of Contents	Page
Imprinter Operating Instructions	2-3
Changing Character Dial Instructions	4
Line and Letter Charts	5-9
1/16"	5
3/32"	6
1/8"	7
3/16"	8
1/4"	9
Assembly Drawings	10-11
Repair Parts List	12
Trouble Shooting	13
Kits	14

Operating Instructions



ID200 Series Imprinter



The I.D Tag Imprinter

The imprinter is an easy-to-use machine for stamping data neatly and uniformly on I.D tags. Familiarize yourself by imprinting some practice pieces. With the 3/32" letter size dial, the large 1 1/2 x 2 1/2 I.D tag can hold as many as 91 characters on 7 lines, plus 30 more using all the space available (see line and letter charts provided in this manual). The small 3/4 x 2" I.D tags will hold 39 characters on 3 lines.

How To Operate Imprinter

Note:

Imprinter is assembled with large anvil already in place. When it becomes necessary to exchange anvils (to print on small tags) be sure that the word "bottom" is faced down on table.

Loosen mounting plate knurled nut. Slide mounting plate to the front and place large I.D tag on top of anvil. Move tag hold-down slides to the inside.

Align the right front edge of the mounting plate with the #1 line of the line indicator and the pointer of the letter indicator with the letter "D".

Spin the character dial to select the desired letter or number to imprint.

Impression depth has been preset at the factory. If deeper impression is desired, turn depth adjustment screw located on top of imprinter counter clockwise.

Actuate operating handle firmly for character impression in I.D tag. Table will index automatically to the next character space.

Caution: Forcing the operating handle may cause damage to the machine.

Use the letter and line charts on pages 5-9 for line and character position.

Refer to website for warranty information: <http://www.band-it-idex.com/warranty.html>

Character Dial Instructions



ID200 Series Imprinter

Remove screw in center of dial and take dial and knob assembly off. Place new dial and knob in position and tighten with retaining screw. Replace line and letter indicator with corresponding parts from kit. Slide table to extreme right and remove table limit screw.

Caution: Table is under tension when pushed all the way to the right.

To safely return table to the left, hold table to the right and push spacer button to allow table to move slowly to the left and expose spacing mechanism. Remove escapement wheel screw, dial washer and escapement wheel and replace with parts from kit. Move table all the way to the right and reassemble table limit screw. To return table to imprinting position, reset line and letter indicator to line and letter chart provided with kit.

Dial Kits:

Dial kits come complete with dial wheel, escapement wheel, dial washer line spacing indicator with decal and a letter spacing indicator with decal.

Catalog Number	Description
ID2816	1/16" Letter Dial Kit
ID2906	3/32" Letter Dial Kit
ID2826	1/8" Letter Dial Kit
ID2836	3/16" Letter Dial Kit
ID2846	1/4" Letter Dial Kit

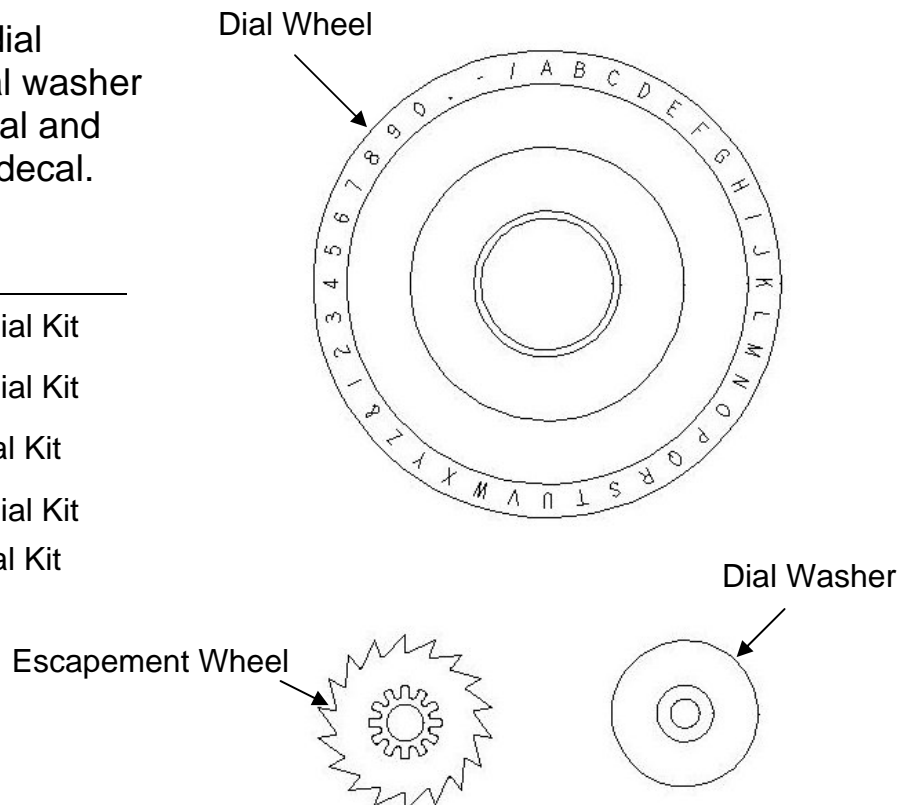

1/16" Line and Letter Position Chart



ID200 Series Imprinter

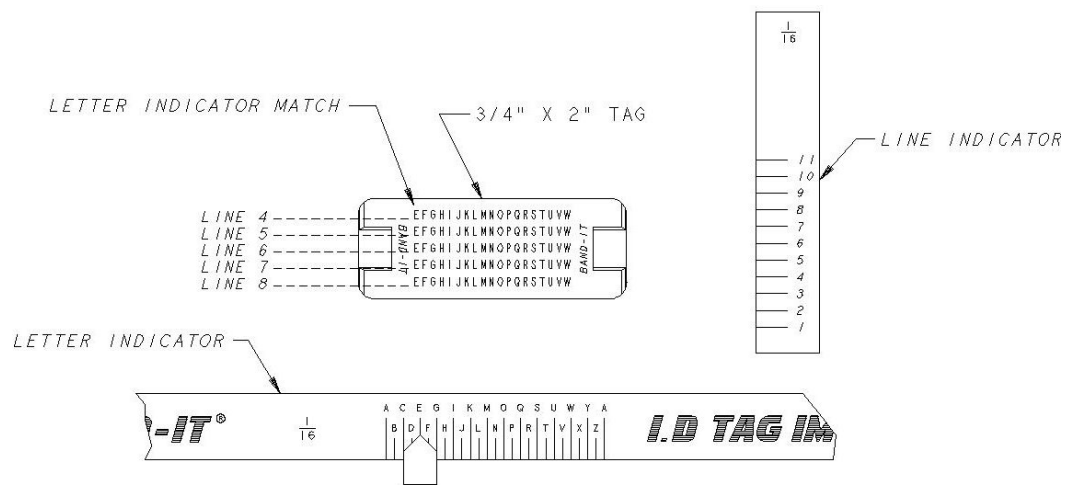
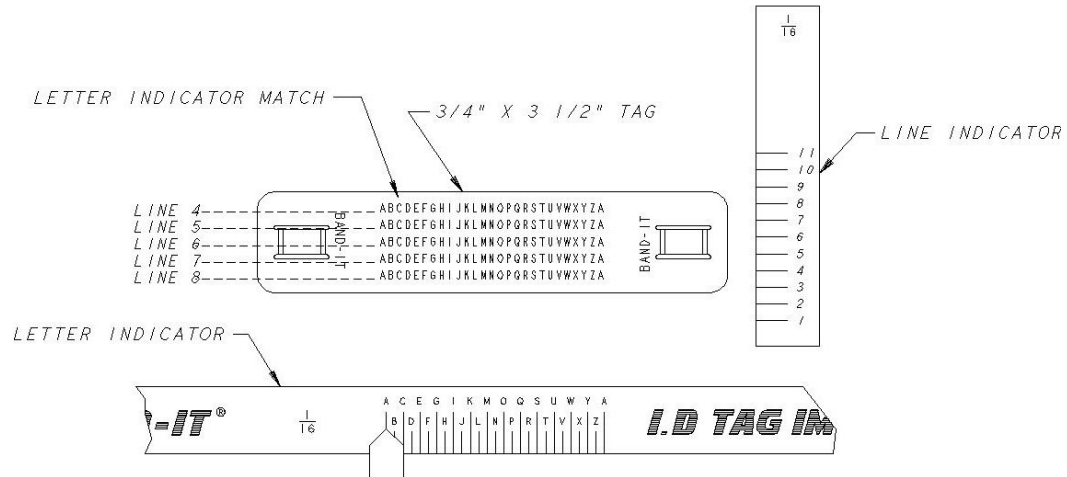
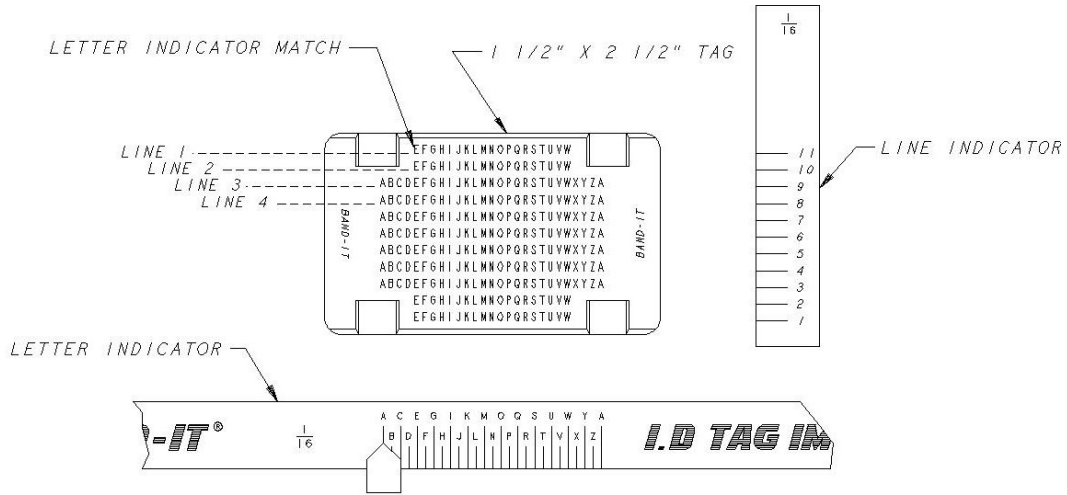

3/32" Line and Letter Position Chart



ID200 Series Imprinter

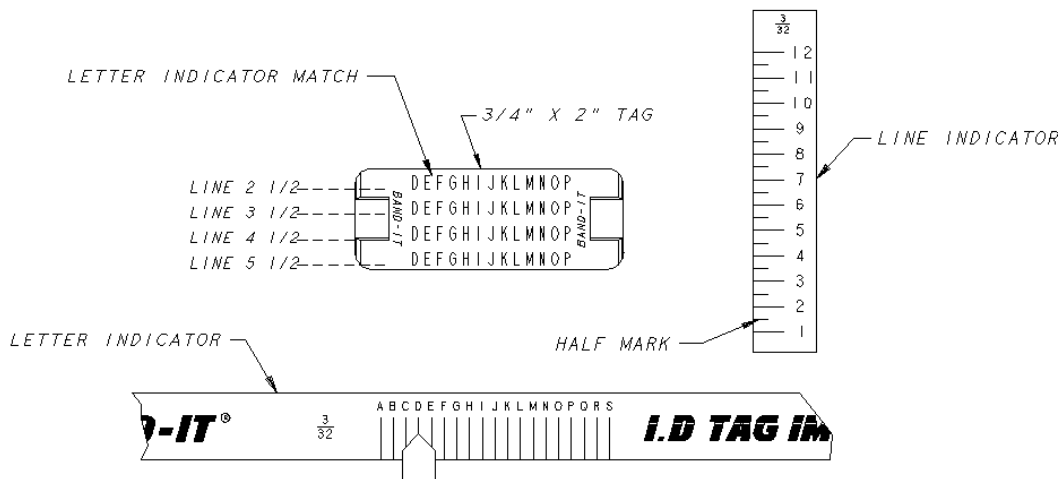
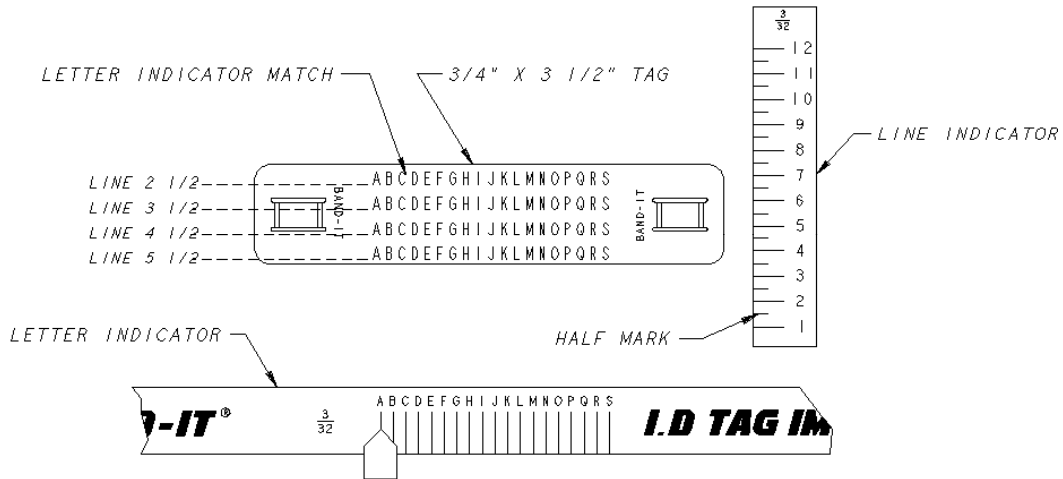
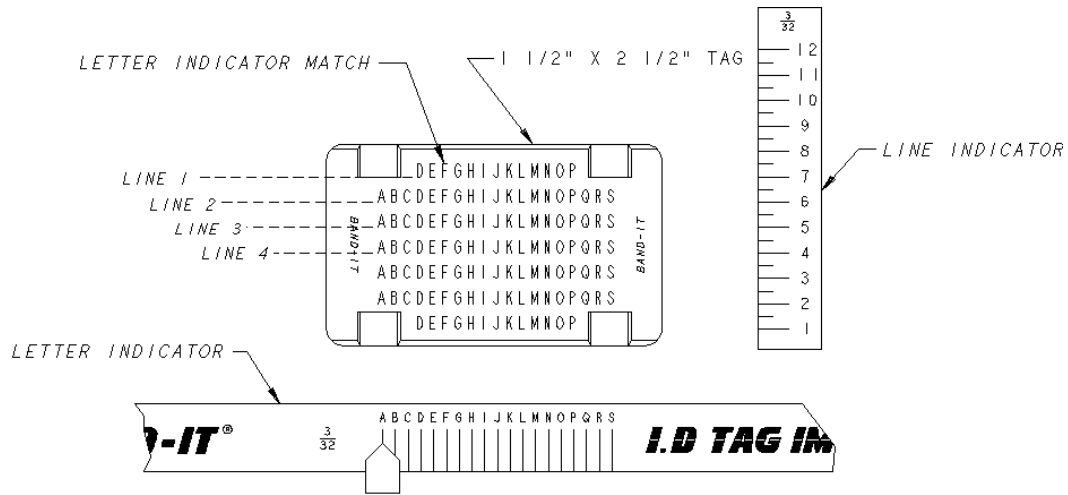

1/8" Line and Letter Position Chart



ID200 Series Imprinter

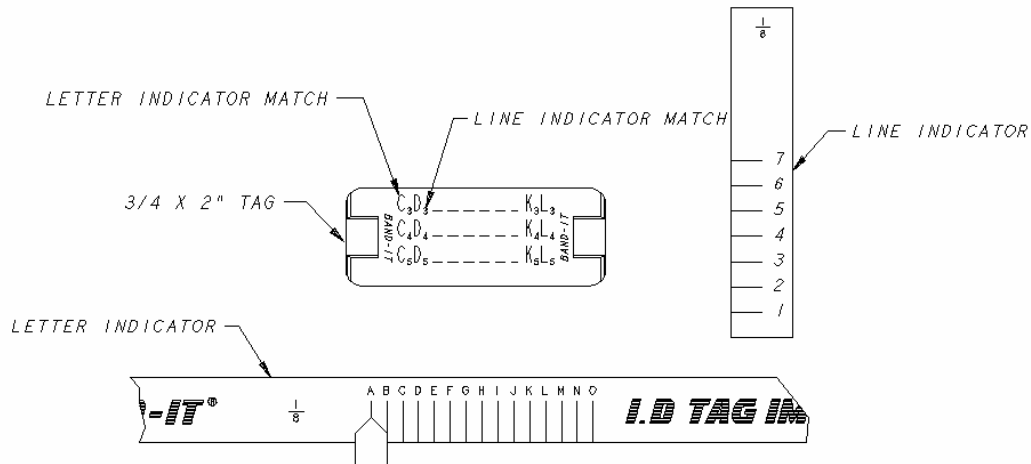
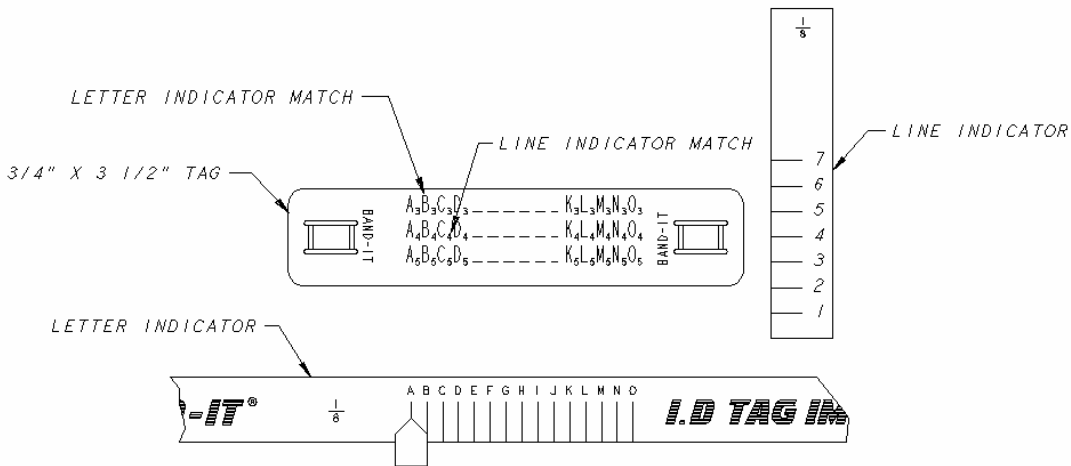
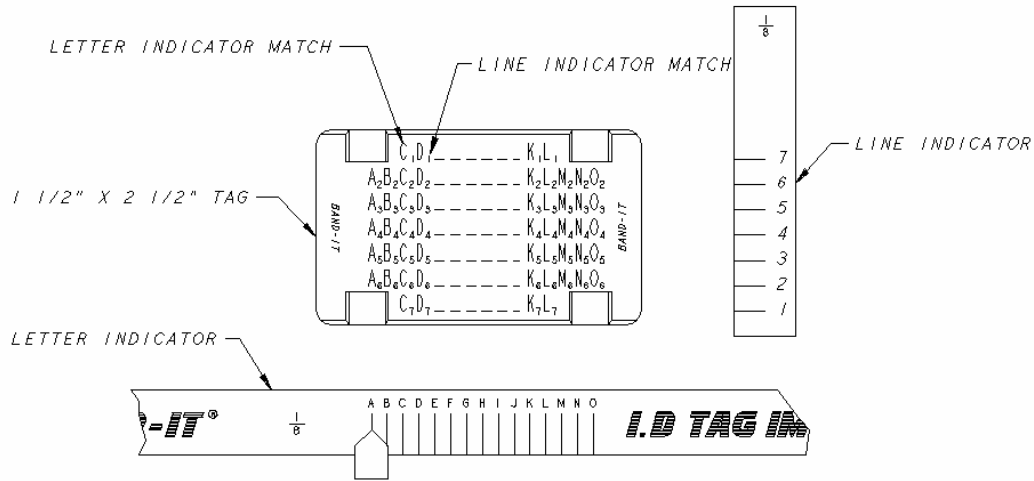

3/16" Line and Letter Position Chart



ID200 Series Imprinter

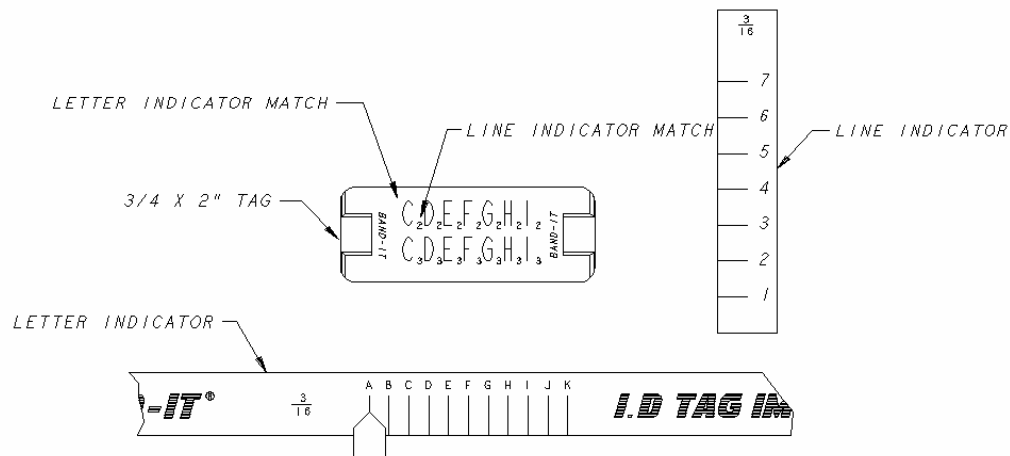
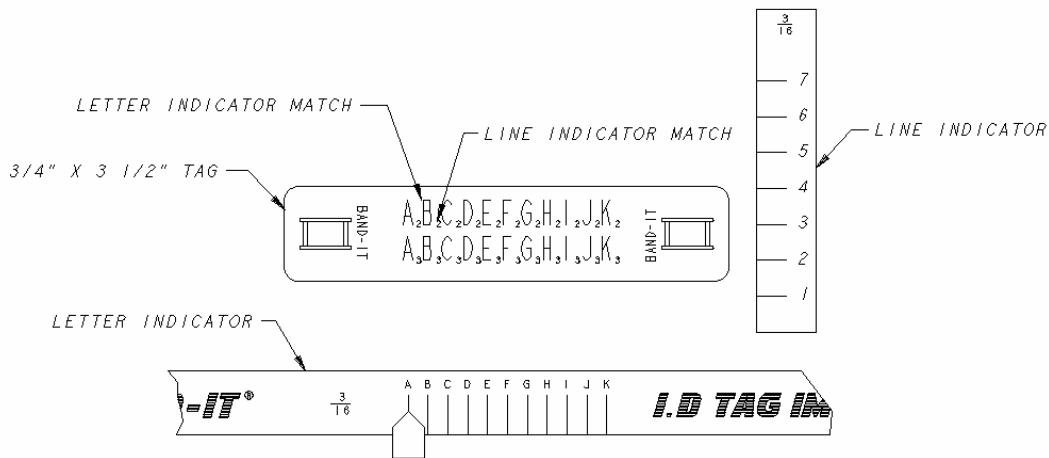
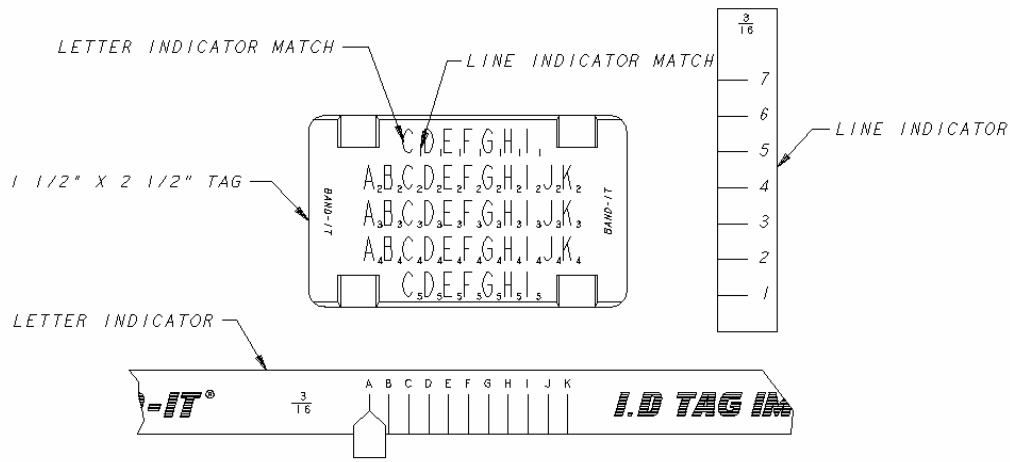

1/4" Line and Letter Position Chart



ID200 Series Imprinter

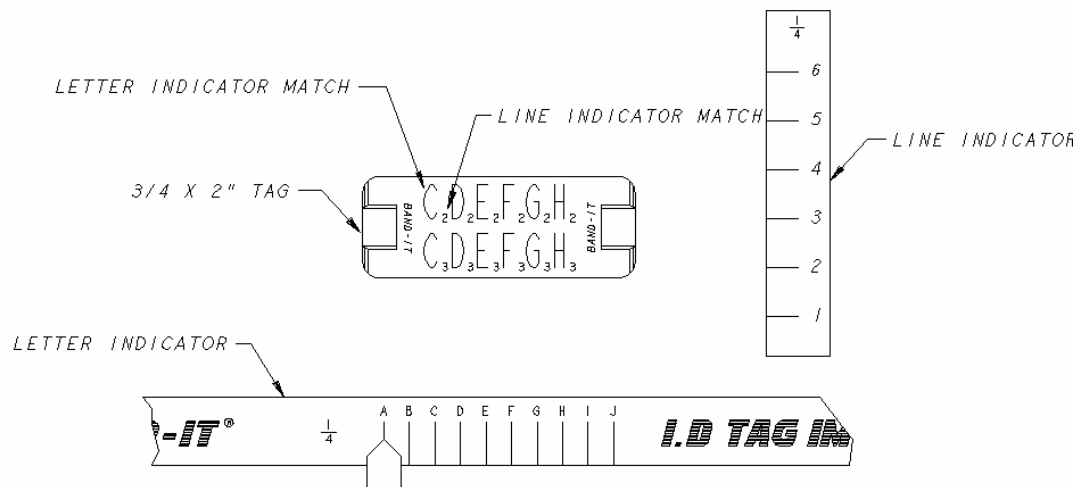
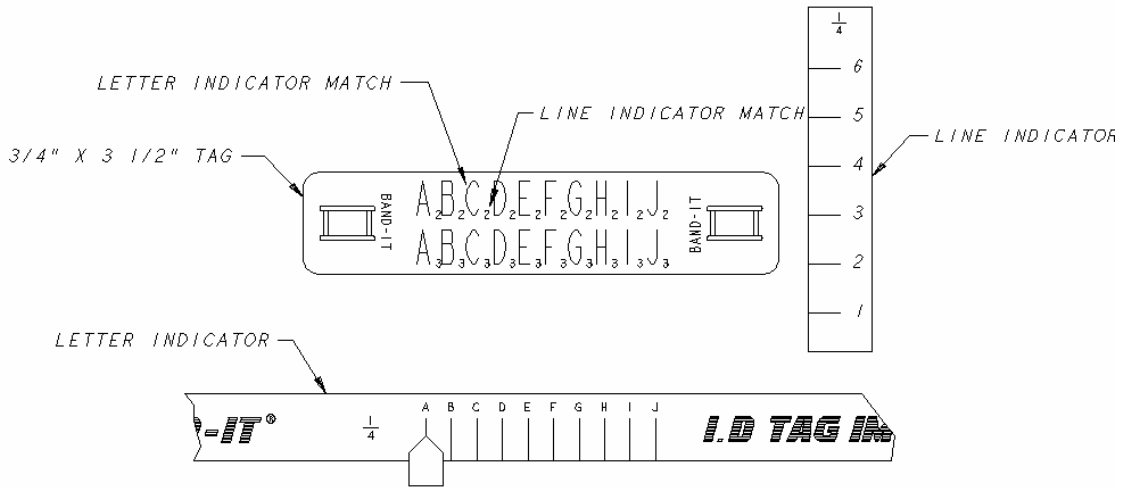
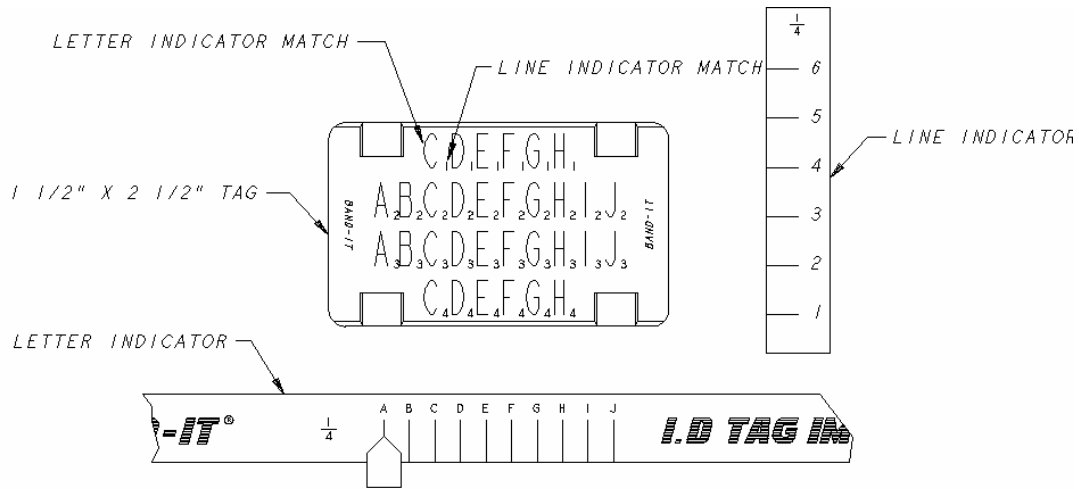

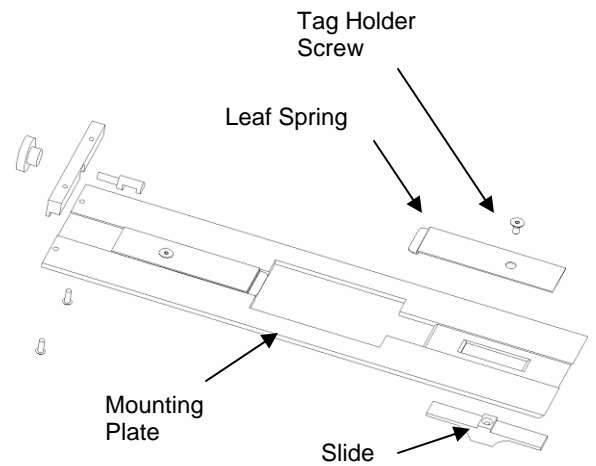
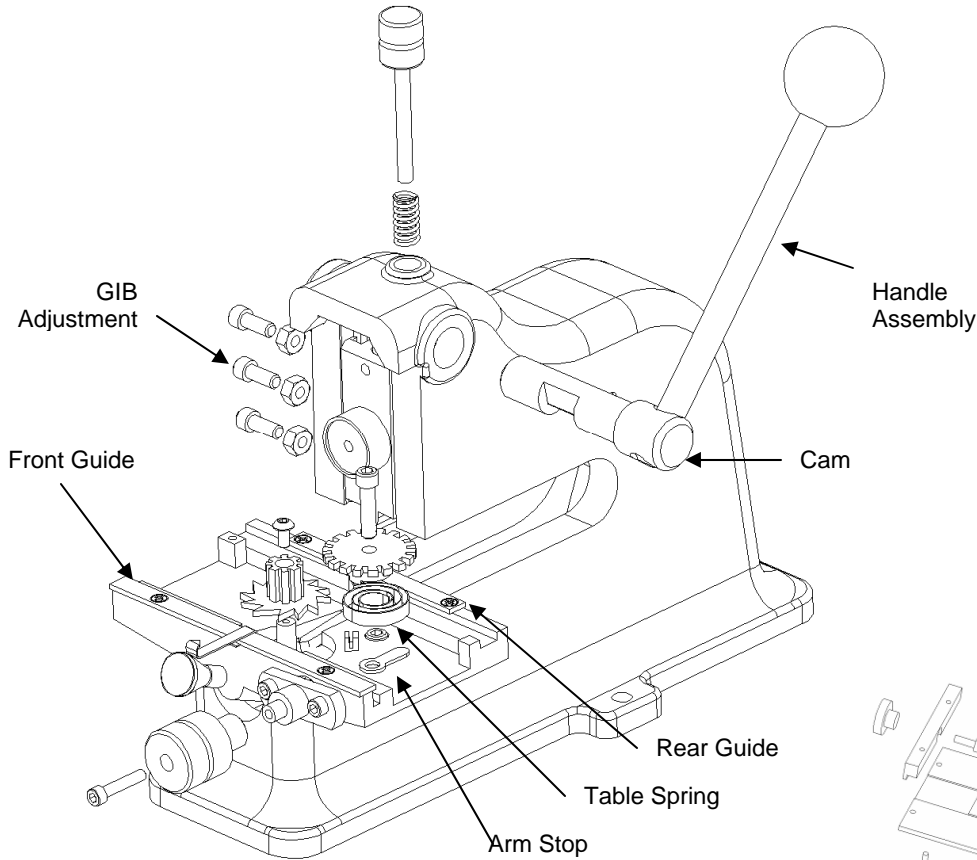

Tag Holder Assembly

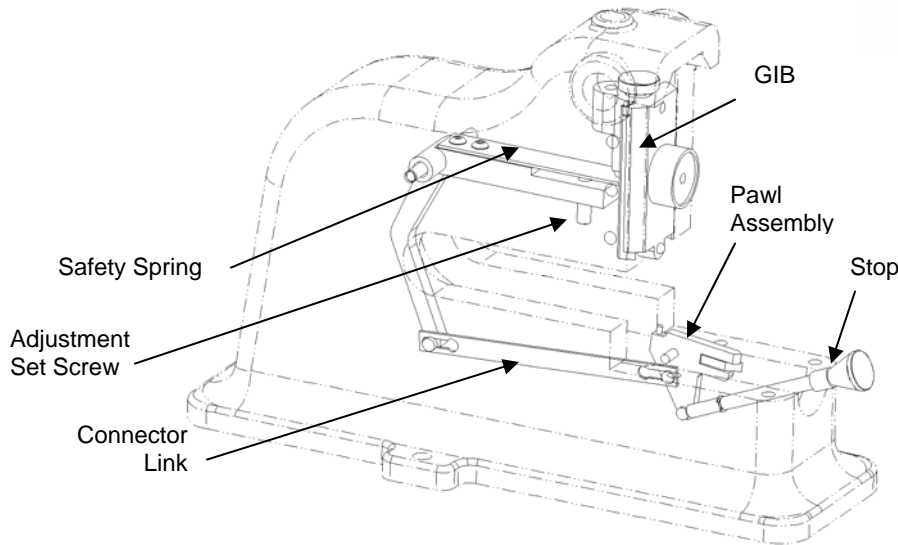

Internal Linkage Detail

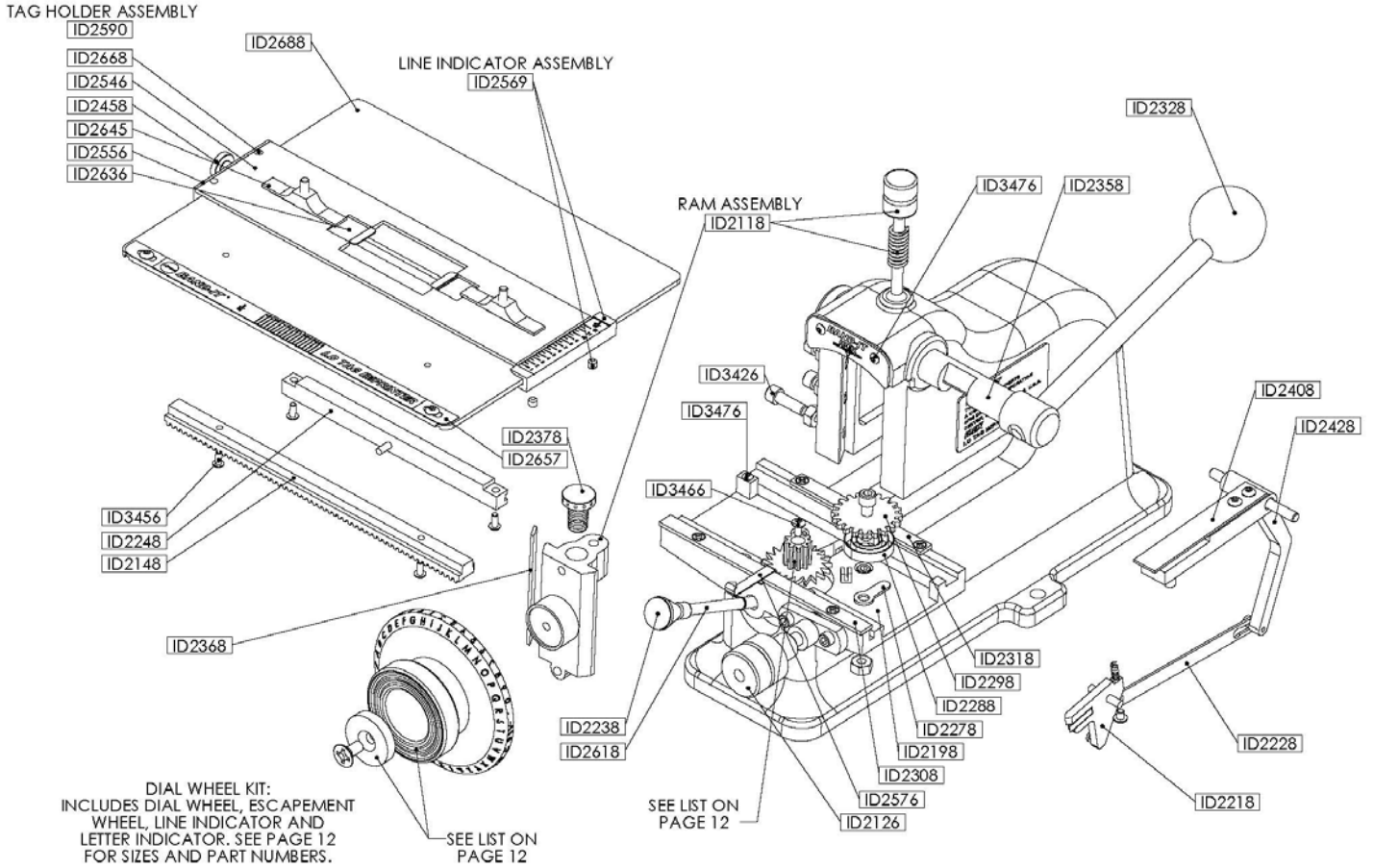



BAND-IT Part	QTY	Description
ID2698	1	1/16" Dial Wheel
ID2918	1	3/32" Dial Wheel
ID2728	1	1/8" Dial Wheel
ID2758	1	3/16" Dial Wheel
ID2788	1	1/4" Dial Wheel
ID2068	1	1/16" Escapement Wheel
ID2078	1	3/32" Escapement Wheel
ID2088	1	1/8" Escapement Wheel
ID2098	1	3/16" Escapement Wheel
ID2108	1	1/4" Escapement Wheel
ID2718	1	1/16" Letter Spacing Decal
ID2518	1	3/32" Letter Spacing Decal
ID2748	1	1/8" Letter Spacing Decal
ID2778	1	3/16" Letter Spacing Decal
ID2808	1	1/4" Letter Spacing Decal
ID2708	1	1/16" Line Spacing Decal
ID2628	1	3/32" Line Spacing Decal
ID2738	1	1/8" Line Spacing Decal
ID2768	1	3/16" Line Spacing Decal
ID2798	1	1/4" Line Spacing Decal
ID2588	1	Anvil, .75 X 2.0 Tag
ID2598	1	Anvil, 1.5 X 2.5 Tag
ID2898	1	Anvil, .75 X 3.5 Tag
ID2816	1	Dial Kit, 1/16" Letter
ID2906	1	Dial Kit, 3/32" Letter
ID2826	1	Dial Kit, 1/8" Letter
ID2836	1	Dial Kit, 3/16" Letter
ID2846	1	Dial Kit, 1/4" Letter

Trouble Shooting



ID200 Series Imprinter

Problem	Probable Cause	Solution
Improper line location	Loose or misaligned line indicator.	Line setup edge of mounting plate with bottom of table anvil (Page 2). Lock tag holder in place with knurled nut. Line first line of line indicator with bottom right corner of mounting plate. Tighten the 2 set screws on the bottom of the line indicator.
Letters not in a straight line	Mounting plate not locked in place tight.	Check the knurled nut on tag holder, it must be tight.
	Mounting plate bowed when locked in place.	With mounting plate in locked position, loosen 2 set screws on bottom of line indicator. Line indicator will move slightly to the right. Retighten the 2 set screws.
Table will not index	Operating handle not returned to original position.	After imprinting each character, the operating handle must be returned to the neutral position (ram in 'up' position).
	Table will not index when handle is returned to original position.	Remove table per instructions on page 4. Turn the imprinter upside down. Turn adjustment set screw ¼ turn clockwise (See page 10). Check indexing of table, turn screw more if needed.
	Table slides left instead of indexing.	Remove table per instructions on page 4. Turn the imprinter upside down. Turn adjustment set screw ¼ turn counter-clockwise (See page 10). Check for indexing of table, turn screw more if needed.
Full letter not printed	GIB needs adjusting.	Loosen all 3 GIB adjustment nuts and screws. Evenly retighten screws. Retighten nuts. (See page 10)
Small tag: Letters not in a straight line	Letter impression too deep.	See letter depth.
Letter depth incorrect	Depth adjustment screw.	Turn depth adjustment screw clockwise to lighten impression, counter-clockwise to deepen.
	Capstan screw.	If the full range of the depth adjustment screw does not result in desired impression: Remove character dial wheel and loosen set screw on front of ram. Turn the capstan screw clockwise for a lighter impression, counter-clockwise for deeper. Adjust depth adjustment screw and check impression. Retighten set screw on ram.

BAND GUIDE

CATALOG NUMBER	DESCRIPTION	WEIGHT LBS.
ID285	BAND GUIDE KIT	.481

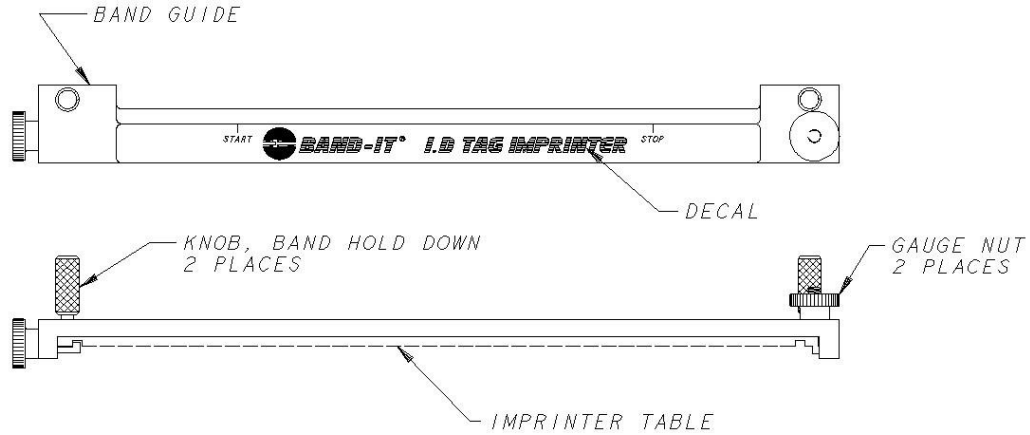

TAG

CATALOG NUMBER	DESCRIPTION	WEIGHT LBS.
ID300	I.D TAG KIT	21.5

KIT CONTAINS:

- ONE TIE-LOKTOOL
- 200 I.D TAGS (3/4" X 2")
- 100 I.D TAGS (1 1/2" X 2 1/2")
- 100 I.D TAGS (3/4" X 3 1/2")
- 100 TIE-LOKS (1/4" X 8")
- 200 TIE-LOKS (1/4" X 14 1/2")
- 100 TIE-LOKS (1/4" X 21")

